



# Air-Cooled Thermopile Sensors to 150 W

## Convection, Air-Cooled Thermopile Sensors for Measuring Laser Power to 150 W

These air-cooled, surface absorbing sensors are intended for measurement of low to medium power pulsed and CW lasers from the 10 mW to 150 W power range.

Convection cooling makes them simple to operate as well as mechanically compact. Product numbers ending in "X" are specifically optimized for use with excimer lasers operating in the ultraviolet (150 nm to 400 nm).

The DB-25 sensor models are compatible with LabMax-Pro, LabMax-TOP/TO, FieldMaxII-TOP/TO/P, and FieldMate meters.

### FEATURES

- Maximum powers from 2 W to 150 W
- Minimum power down to 10 mW
- Broadband and Excimer coatings
- Convective air-cooled
- 0.15  $\mu\text{m}$  to 11  $\mu\text{m}$  spectral range
- 19 mm and 50 mm diameter active areas
- DB25 (meter required)
- RoHS Compliant

### APPLICATIONS

- Medical
- Scientific
- Industrial
- General Laser Power Measurement from mW to 150 W



# Air-Cooled Thermopile Sensors to 150 W Datasheet

SPECIFICATIONS	PM2	PM10	PM30
Wavelength Range ( $\mu\text{m}$ )	0.25 to 11		
Power Range	10 mW to 2 W	10 mW to 10 W	100 mW to 30 W
Long-Pulse Joules Range (J)	0.5 to 2	0.5 to 10	0.5 to 50
Maximum Intermittent Power (<5 min.) (W)	5	30	50
Resolution (mW)	1	1	10
Maximum Power Density ( $\text{kW}/\text{cm}^2$ )	6		
Maximum Energy Density ( $\text{mJ}/\text{cm}^2$ )	600, 1064 nm, 10 ns		
Response Time (sec.)	2		
Detector Coating	Broadband		
Active Area Diameter (mm)	19		
Calibration Uncertainty (%) (k=2)	$\pm 1$		
Calibration Wavelength (nm)	514		
Cooling Method	Air-cooled		
Cable Type	PM DB-25		
Cable Length (m)	2		
Part Number	1098329 <sup>1</sup>	1097901 <sup>1</sup>	1098314 <sup>1</sup>

<sup>1</sup> C24 Quick Ship program: eligible for next business day shipment.

## MECHANICAL SPECIFICATIONS

### PM2

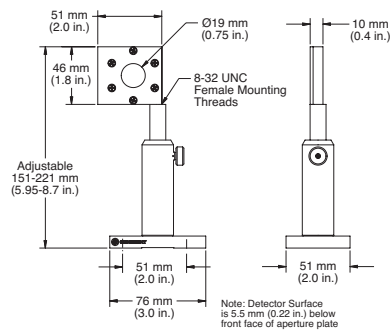

### PM10

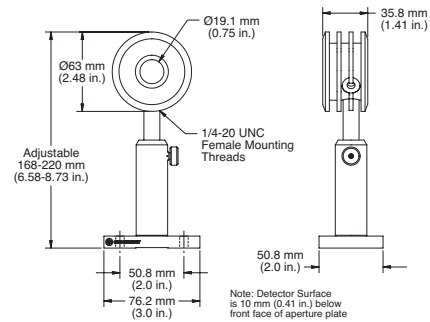

### PM30

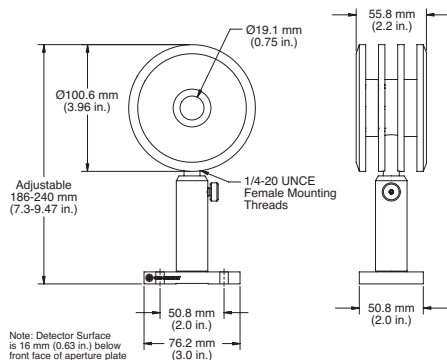

SPECIFICATIONS	PM100-19C <sup>1</sup>	PM150	PM150-50
Wavelength Range (μm)	0.25 to 11		
Power Range	300 mW to 100 W	300 mW to 150 W	300 mW to 150 W
Long-Pulse Joules Range (J)	1 to 100	1 to 150	1 to 150
Maximum Intermittent Power (<5 min.) (W)	100	300	300
Resolution (mW)	30		
Maximum Power Density (kW/cm <sup>2</sup> )	6		
Maximum Energy Density (mJ/cm <sup>2</sup> )	600, 1064 nm, 10 ns		
Response Time (sec.)	2	2	5
Detector Coating	Broadband		
Active Area Diameter (mm)	19	19	50
Calibration Uncertainty (%) (k=2)	±1		
Calibration Wavelength (nm)	514		
Cooling Method	Air-cooled		
Cable Type	PM DB-25		
Cable Length (m)	2		
Part Number	1098483	1098407	109839

<sup>1</sup> This sensor is designed for intermittent use only.

## MECHANICAL SPECIFICATIONS

### PM100-19C

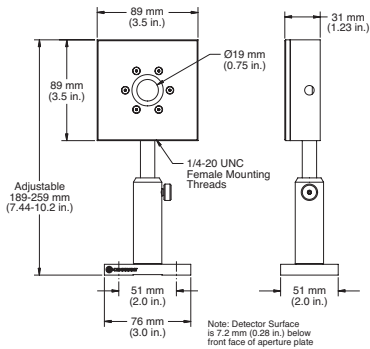

### PM150

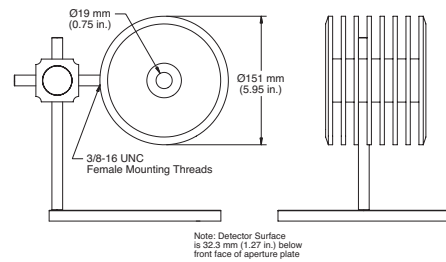

### PM150-50

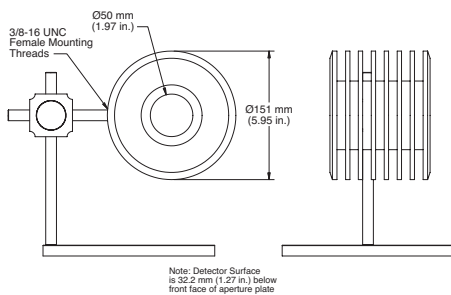

SPECIFICATIONS	PM2X	PM10X	PM30X
Wavelength Range (μm)	0.15 to 1		
Power Range	10 mW to 2 W	10 mW to 10 W	100 mW to 30 W
Long-Pulse Joules Range (J)	0.5 to 2	0.5 to 10	0.5 to 50
Maximum Intermittent Power (<5 min.) (W)	5	30	50
Resolution (mW)	1	1	10
Maximum Power Density (kW/cm <sup>2</sup> )	6		
Maximum Energy Density (mJ/cm <sup>2</sup> )	600, 1064 nm, 10 ns		
Response Time (sec.)	2		
Detector Coating	UV		
Active Area Diameter (mm)	19		
Calibration Uncertainty (%) (k=2)	±1		
Calibration Wavelength (nm)	514		
Cooling Method	Air-cooled		
Cable Type	PM DB-25		
Cable Length (m)	2		
Part Number	1098457	1098423	1098498 <sup>1</sup>

<sup>1</sup> C24 Quick Ship program: eligible for next business day shipment.

## MECHANICAL SPECIFICATIONS

### PM2X

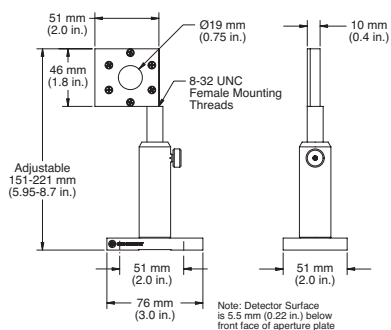

### PM10X

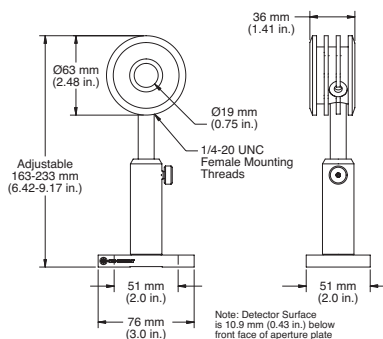

### PM30X

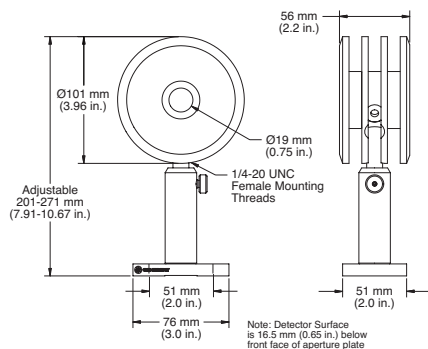

SPECIFICATIONS	PM150X
Wavelength Range (μm)	0.15 to 1
Power Range	300 mW to 150 W
Long-Pulse Joules Range (J)	1 to 150
Maximum Intermittent Power (<5 min.) (W)	300
Resolution (mW)	30
Maximum Power Density (kW/cm <sup>2</sup> )	6
Maximum Energy Density (mJ/cm <sup>2</sup> )	600, 1064 nm, 10 ns
Response Time (sec.)	5
Detector Coating	UV
Active Area Diameter (mm)	50
Calibration Uncertainty (%) (k=2)	±1
Calibration Wavelength (nm)	514
Cooling Method	Air-cooled
Cable Type	PM DB-25
Cable Length (m)	2
Part Number	1098455

## MECHANICAL SPECIFICATIONS

### PM150X

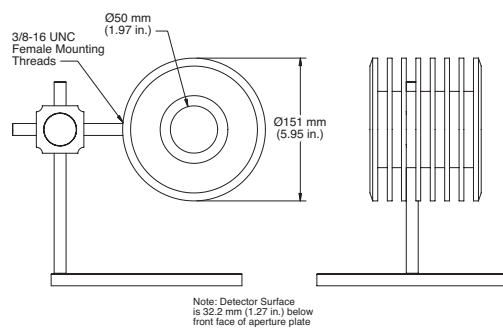

Coherent, Inc.,  
 5100 Patrick Henry Drive Santa Clara, CA 95054  
 p. (800) 527-3786 | (408) 764-4983  
 f. (408) 764-4646

[tech.sales@coherent.com](mailto:tech.sales@coherent.com) [www.coherent.com](http://www.coherent.com)

Coherent follows a policy of continuous product improvement. Specifications are subject to change without notice. Coherent's scientific and industrial lasers are certified to comply with the Federal Regulations (21 CFR Subchapter J) as administered by the Center for Devices and Radiological Health on all systems ordered for shipment after August 2, 1976.

Coherent offers a limited warranty for all Thermopile Sensors. For full details of this warranty coverage, please refer to the Service section at [www.coherent.com](http://www.coherent.com) or contact your local Sales or Service Representative.  
 MC-045-19-0M1119 Copyright ©2019 Coherent, Inc.